



Models CDC-FDF & CDC-FDR

INSTALLATION GUIDE FOR:

CD CHANGER INTERFACE CABLE for FORD VEHICLES

Form No. 128-5315

CAUTION: FOLLOW THE CONNECTION SEQUENCE DESCRIBED BELOW TO ENSURE PROPER RECOGNITION OF THE CD CHANGER BY THE FACTORY RADIO.
DO NOT FORCE CONNECTORS TOGETHER. LINE UP LOCATING TABS AND CAREFULLY MATE CONNECTORS.

INSTALLATION INSTRUCTIONS FOR THE CDC-FDR: (Fig. 1)

IMPORTANT : Vehicles with electronic heating/AC controls may experience intermittent operation of these controls when the CD Changer is disconnected.

1. Mount the CD changer at the desired location in the trunk following the installation instructions supplied with the CD changer.
2. Carefully connect the 8-pin circular DIN connector from the CDC-FDR to the mating socket on the CD Changer.
3. Route the CDC-FDR cable toward the factory tuner/amplifier pack located in the rear left wheel well.
4. With the vehicle off, unplug the power/speaker connector from the tuner/amplifier pack.
5. Carefully connect the data cable from the CDC-FDR to the mating socket on the tuner/amplifier pack.
6. Carefully connect the vehicle side power/speaker cable to the mating connector on the CDC-FDR.
7. Carefully connect the power/speaker connector from the CDC-FDR to the mating socket on the tuner/amplifier pack.

INSTALLATION INSTRUCTIONS FOR THE CDC-FDF: (Fig. 2)

IMPORTANT : When mounting the CD Changer in the rear of the vehicle, it may be necessary to purchase separately the **AK-98-CDA**, data cable adaptor. The **AK-98-CDA** allows the 20-foot data cable supplied with the CD Changer to connect to the CDC-FDF.

1. Mount the CD Changer at the desired location either in the center console (CDC-620 only) or in the rear of the vehicle. Refer to the installation instructions supplied with the CD Changer.
2. Carefully connect the 8-pin circular DIN connector from the CDC-FDF to the mating socket on the CD Changer. The AK-98-CDA may be required when rear mounting the CD Changer.
3. Route the CDC-FDF cable toward the factory radio.
4. Remove the factory radio from the dash panel using the factory removal tools.
5. Unplug both the power/speaker and CD Changer connectors from the rear of the radio.
6. Carefully connect the vehicle power/speaker and CD Changer connectors to the respective mating connectors on the CDC-FDF.
7. Carefully connect the power/speaker and CD Changer connectors of the CDC-FDF to the respective mating connectors at the rear of the radio.

OPERATION CHECK:

1. Load CD's into the CD Changer cartridge and insert the cartridge into the changer.
2. Start vehicle and allow CD Changer to cycle.
Perform a brief functional test to verify proper operation according to the owner's manual.

CDC-FDR Installation Diagram (Fig. 1)

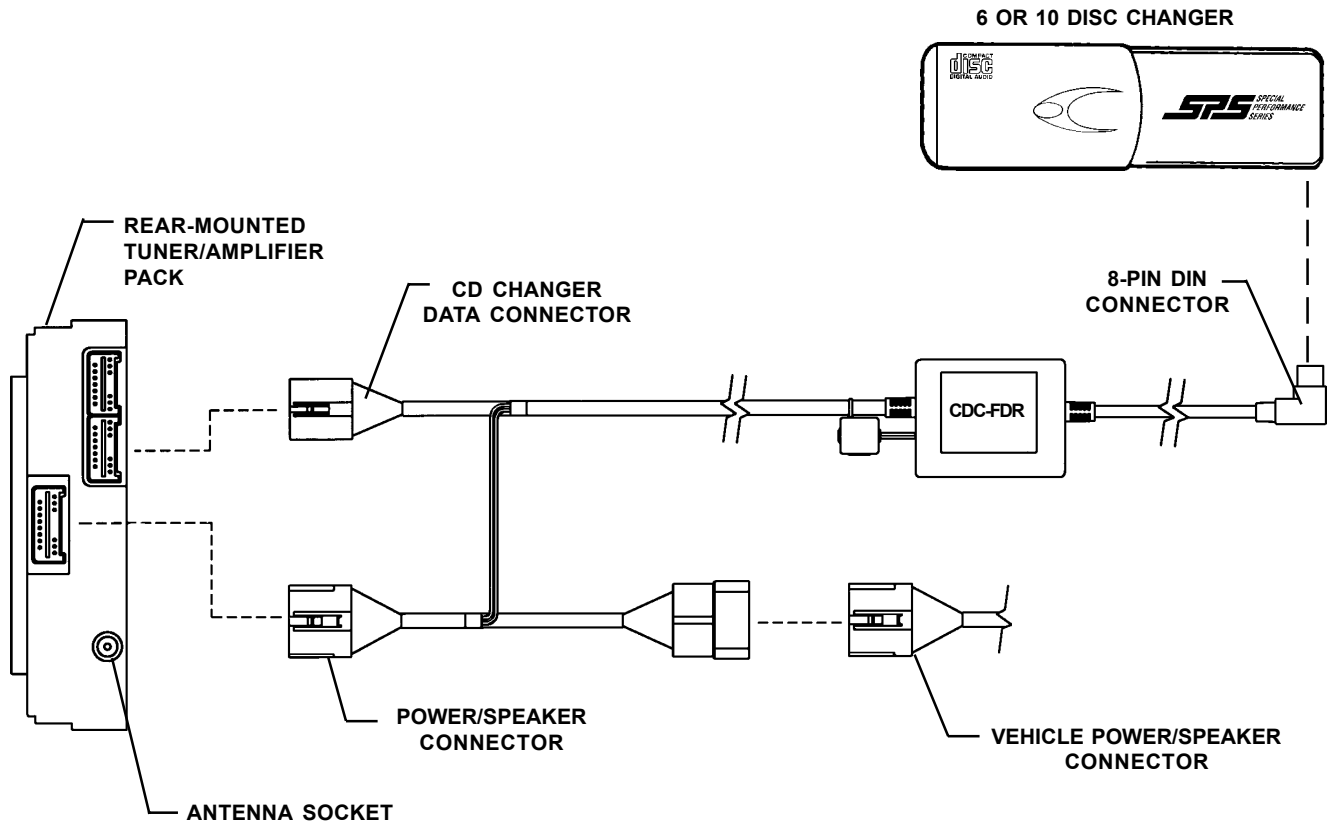

FACTORY RADIO REAR VIEW

CDC-FDF Installation Diagram (Fig. 2)

